



STEEL SQUARE | INGROUNDS

PRODUCT CODE

PROJECT

TYPE

PERFORMANCE
in LIGHTING

powered by
GEWISS



Company

Performance in Lighting USA, located in Conyers, GA, is part of an international group of companies headquartered in Verona, Italy.

The group was formed from a number of well-established technical lighting companies from various countries. Performance in Lighting has a wide sales and distribution network operating in over 100 countries worldwide. Production facilities are located in Verona Italy, Bergamo Italy, Goslar Germany, Brussels Belgium, Conyers GA USA. Sales/distribution subsidiaries are located in England, Holland, France, Finland, Spain, Portugal, Australia, Dubai and Japan.

Recognized for its unique professional approach and technical know-how, Performance in Lighting has combined its international experience and technical expertise to become a worldwide leader in its industry. The group offers various lighting solutions worldwide for many applications including interior, exterior, residential, commercial, and sports lighting providing options to satisfy both architectural and engineering requirements.

Performance in Lighting USA concentrates on specification grade luminaires designed to provide a vast array of lighting solutions. Our concentration is outdoor products for illuminating commercial spaces from structural facades to parking areas. We strive to meet the demands of today's lighting community offering made in USA products, European designed with clean, contemporary aesthetics along with aggressive price points and fast lead times.

Pronto Program

PERFORMANCE IN LIGHTING offers a wide range of quick ship fixtures through the Pronto Program and a host of options to fit within the unique budget of your next project.





Overview

Click the QR-code for latest information.

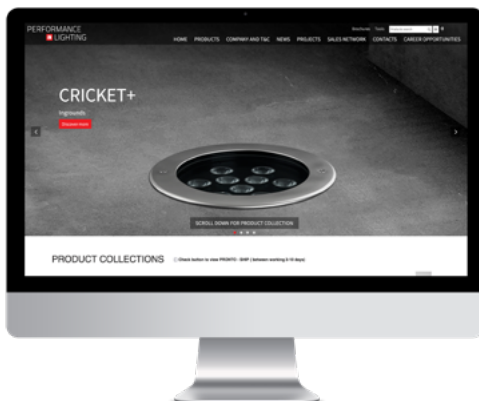

Website

Please visit our web site www.performanceinlighting.com/us/us/ for the latest updated versions available.



5-year warranty

All products are covered by a 5-year warranty, provided that they are used and maintained according to instructions. Focus on quality, safety and product lifetime/longevity are the essential objectives of PERFORMANCE IN LIGHTING. For additional information, email info.usa@pil.lighting

STEEL SQUARE

Materials beyond standard

The formal language is simple and subordinated to the architecture: the luminaire is not the center of the scene, it is the light. Hence, light becomes the leading actor of the tale of this series.

The STEEL series is designed for the diverse needs of inground drive-over luminaires. The precision cast stainless steel trims are the elegant common element to all the configurations which characterize and make the individual product application unique. A bright, elegant and stylish element in different shapes and sizes that enhances spaces, marks paths, illuminates architecture and exalts details, creating the right light in every context. The stainless steel that characterizes this series is a robust material resistant to any climate condition. STEEL fixtures are available in round and square shapes, with a range of power levels and optics that enhance the potential and flexibility of the product. Thanks to the availability of COMPACT reduced depth recessed models, this series can be used with maximum freedom, even in situation where it is not possible to create the classic drainage hole.





Charter square | Raleigh | North Carolina | USA

STEEL SQUARE

In-ground series. Fixtures consist of:

CONSTRUCTION

- Copper-free die-cast aluminum housing and die-cast corrosion-resistant AISI 316 stainless steel trim.
- Custom MCPCB utilized to maximize heat dissipation and promote long LED life.
- High-transmittance transparent optics.
- Extra-clear, tempered, silk-screened, flat glass diffuser.
- Custom molded, anti-aging gasket(s).
- Stainless steel external hardware.

INSTALLATION

- Available in three standard sizes of 7.8" x 7.8" (STEEL SQUARE 20), 11" x 11" (STEEL SQUARE 28) and 13.4" x 13.4" (STEEL SQUARE 34).
- Pre-wired cable connects luminaire with WATER-STOP connection system, suitable for through wiring. Included cable glands accept cables from Ø0.35" up to Ø0.63".
- Each rough-in kit is provided with a protective faceplate to avoid possible deformations during the installation in concrete to simplify installation.
- Thermoplastic compression-molded rough-in kit to be ordered separately.
- For outdoor inground applications, provide drainage gravel at least 12" below the rough-in or a suitable drainage system.
- Walk-over and Drive-over rated.

OPTICS

- Circular Intensive (C/I) and Elliptical (ELL) optics, both including a field settable optic system ($\pm 7^\circ$).

ELECTRICAL

- Input voltage: 120-277 V (50 / 60 Hz), integral driver.

OPTIONS

- The luminaire may be configured with numerous options and multiple standard finishes. Not all options are available in all configurations. Consult factory for more information about specification sheet details.

LISTINGS

- UL Wet location listed. IP67 rated.
- Product meets Buy American requirements within ARRA.
- Photometric data measured according to UNI EN 13032-1/4 and IES LM-79-08
- Actual performance may differ as a result of the end-user environment and application. All values are design or typical values, measured under laboratory conditions at 25 °C. Specifications are subject to change without notice.

WARRANTY

- 5-year limited warranty. Complete warranty terms located at www.performanceinlighting.com



STEEL SQUARE 34



STEEL SQUARE 28



STEEL SQUARE 20



STEEL SQUARE

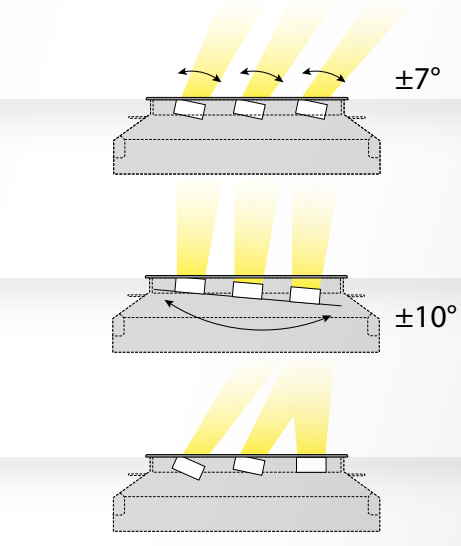

In all STEEL SQUARE versions, the LEDs are positioned on adjustable bars that enable the light to be directed, concentrating it in the chosen points. The bars must be directed before mounting the glass and the closing ring.

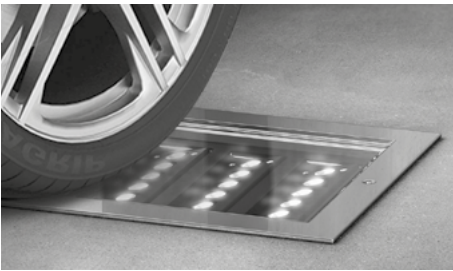

Walk-over and driver-over rated.



Copper-free die-cast aluminum housing and die-cast corrosion-resistant AISI 316 stainless steel trim.

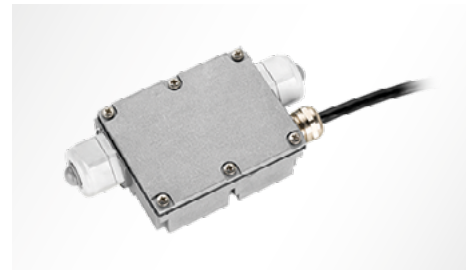

Pre-wired cable connects luminaire with WATER-STOP connection system, suitable for through wiring. Included cable glands accept cables from Ø0.35" up to Ø0.63".

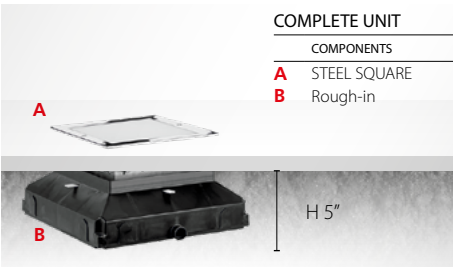

For products that must be mounted on a post, bracket, track or recessed into the wall, it is often necessary to order several different parts (codes) to get the complete configuration.

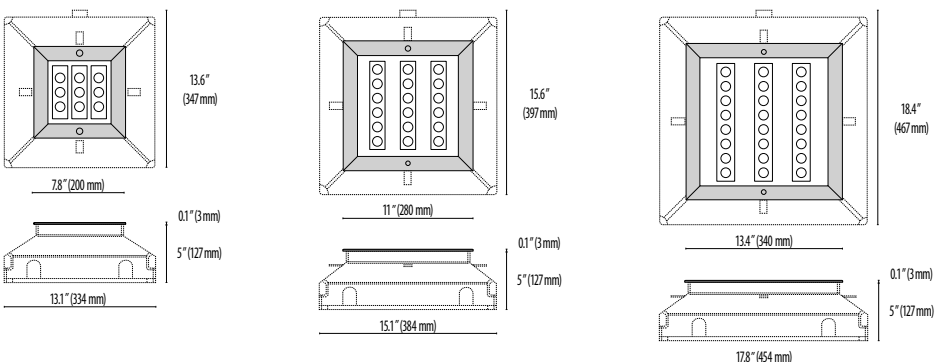

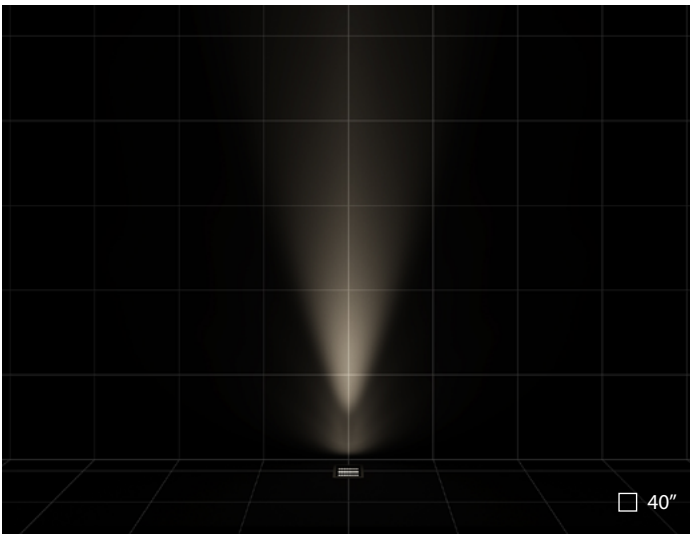

STEEL SQUARE 34 - 24 LED | 8° Circular Intensive optics

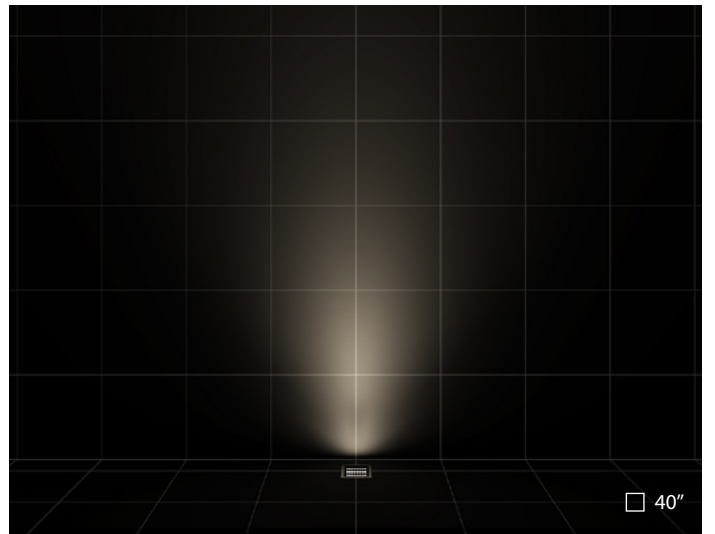

STEEL SQUARE 34 - 24 LED | 10°x45° Elliptical optics

PERFORMANCE
IN LIGHTING

powered by
GEWISS

PERFORMANCE IN LIGHTING
2621 Keys Pointe
Conyers, GA 30013 - United States
Ph 770.822.2115
Fax 770.822.9925

www.performanceinlighting.com