



**STRIP+** | LINEAR SURFACE | LINEAR RECESSED

PRODUCT CODE

---

PROJECT

---

TYPE

---

PERFORMANCE  
**iN** LIGHTING

powered by  
**GEWISS**



## Company

Performance in Lighting USA, located in Conyers, GA, is part of an international group of companies headquartered in Verona, Italy.

The group was formed from a number of well-established technical lighting companies from various countries. Performance in Lighting has a wide sales and distribution network operating in over 100 countries worldwide. Production facilities are located in Verona Italy, Bergamo Italy, Goslar Germany, Brussels Belgium, Conyers GA USA. Sales/distribution subsidiaries are located in England, Holland, France, Finland, Spain, Portugal, Australia, Dubai and Japan.

Recognized for its unique professional approach and technical know-how, Performance in Lighting has combined its international experience and technical expertise to become a worldwide leader in its industry. The group offers various lighting solutions worldwide for many applications including interior, exterior, residential, commercial, and sports lighting providing options to satisfy both architectural and engineering requirements.

Performance in Lighting USA concentrates on specification grade luminaires designed to provide a vast array of lighting solutions. Our concentration is outdoor products for illuminating commercial spaces from structural facades to parking areas. We strive to meet the demands of today's lighting community offering made in USA products, European designed with clean, contemporary aesthetics along with aggressive price points and fast lead times.

## Pronto Program

PERFORMANCE IN LIGHTING offers a wide range of quick ship fixtures through the Pronto Program and a host of options to fit within the unique budget of your next project.





## Overview

Click the QR-code for latest information.

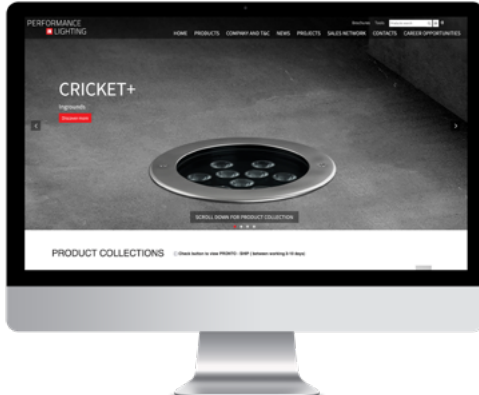

## Website

Please visit our web site [www.performanceinlighting.com/us/us/](http://www.performanceinlighting.com/us/us/) for the latest updated versions available.



## 5-year warranty

All products are covered by a 5-year warranty, provided that they are used and maintained according to instructions. Focus on quality, safety and product lifetime/longevity are the essential objectives of PERFORMANCE IN LIGHTING. For additional information, email [info.usa@pil.lighting](mailto:info.usa@pil.lighting)

# STRIP SQUARE+

## The wall grazer family

Strip Square has been one of our most successful product families, so we've decided to upgrade and enhance it! Welcome, STRIP SQUARE+! Designed around the same low profile, our new STRIP SQUARE+ is now upgraded to include various options to meet a wide variety of application needs. This workhorse now offers additional choices such as RGBW, Dynamic Tunable White, Asymmetric, and multiple optics. Whether you're looking to illuminate your building by incorporating our surface mount version with its adjustable arm or use the in-ground, drive over version, this minimalistic design will integrate well into almost any space and highlight your architectural area. The quick-connect component makes installation a contractor's dream while maintaining watertight integrity and eliminating the need to open the fixture during installation.





Verbindingstunnel van heekgarage | Enschede | Netherlands

# STRIP SQUARE+

Linear surface mount (STRIP+) and linear in-ground (STRIP+ INGROUND) series. Fixtures consist of:

## CONSTRUCTION

- Copper-free aluminum die-cast end-caps, extruded, and anodized housing.
- Copper-free aluminum extruded and anodized field-adjustable mounting bracket for aiming the luminaire.
- Custom MCPCB utilized to maximize heat dissipation and promote long LED life.
- High-transmittance transparent optics.
- Extra-clear, tempered, silk-screened, flat glass diffuser.
- Custom molded, anti-aging gasket(s).
- Stainless steel external hardware.

## INSTALLATION

- Available in five standard lengths of 11.1", 20.8", 30.7", 40.6" and 50.6" (STRIP SQUARE).
- Pre-wired factory sealed cable for external electrical connection included.
- Available in four standard lengths of 21.7", 31.6", 41.5" and 51.4" (STRIP SQUARE INGROUND).
- Pre-wired cable connects luminaire with WATER-STOP connection system, suitable for through wiring. Included cable glands accept cables from Ø0.35" up to Ø0.63".
- Stainless steel grounding tether included.
- Each rough-in kit is provided with a protective faceplate to avoid possible deformations during the installation in concrete to simplify installation.
- Walk-over and Drive-over rated.

## ELECTRICAL

- Input voltage: 120-277 V (50 / 60 Hz), integral 0-10 V dimming driver.
- Input voltage: 48 V DC, separate driver (Dynamic Color Change versions).

## OPTICS

- Circular Intensive (C/I), Elliptical (ELL), Asymmetrical Medium (A18/M), Dynamic color change (RGBW), and Tunable White (TW) overall optics and light distributions, including a filed adjustable field bracket ( $\pm 90^\circ$ ), with double securing set screws.

## OPTIONS

- The luminaire may be configured with numerous options and multiple standard finishes. Not all options are available in all configurations. Consult factory for more information about specification sheet details.

## LISTINGS

- UL Wet location listed. IP66 rated.
- UL Wet location listed. IP67 rated (INGROUND versions).
- Product meets Buy American requirements within ARRA.
- Consult factory for which version qualifies for the PRONTO-SHIP program. All Rough-Ins are available to ship within 48-72 hrs. Orders must be marked "PRONTO."
- Photometric data measured according to UNI EN 13032-1/4 and IES LM-79-08
- Actual performance may differ as a result of the end-user environment and application. All values are design or typical values, measured under laboratory conditions at 25 °C. Specifications are subject to change without notice.

## WARRANTY

- 5-year limited warranty. Complete warranty terms located at [www.performanceinlighting.com](http://www.performanceinlighting.com)



STRIP SQUARE+



STRIP SQUARE+ INGROUND

# STRIP SQUARE+



Copper-free aluminum die-cast end-caps, extruded and anodized housing, and field-adjustable mounting bracket (WALL) for aiming the luminaire.



Pre-wired cable is factory sealed to housing with a cable gland allowing external electrical connections.



Available in three standard beam angle of 12° x 12° (C/I), 10° x 45° (ELL) and 40° x 40° (RGB versions) including aimable, field movable bracket ( $\pm 90^\circ$ ) with double securing set screws.

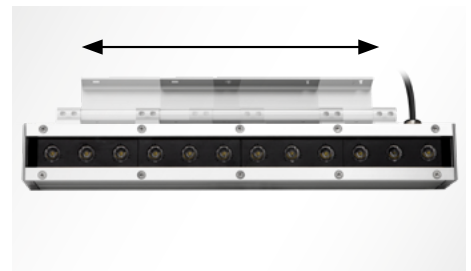

Wall mounting bracket adjustable all along the housing.



"EasyLighting"  
App (free)

EasyLighting is an application that uses a WIFI network to control, adjust, and customize the lighting color or CCT, brightness, and the rate of change. With this application you can control EasyLighting products through most mobile devices.



RGBW

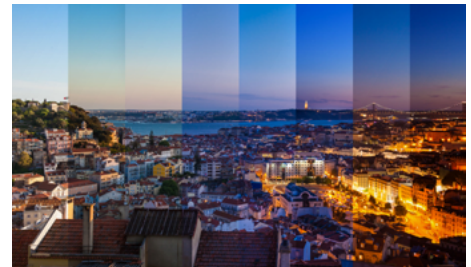

Tunable White

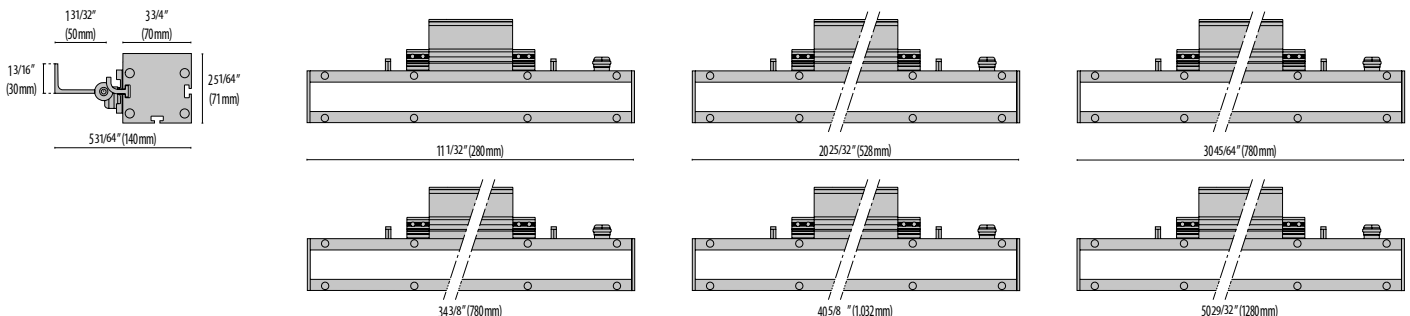



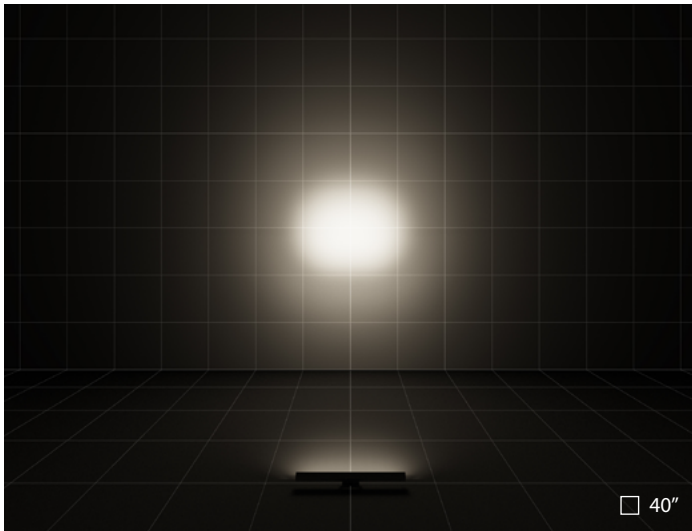

STRIP SQUARE+ | C/I 9° Circular Intensive optics

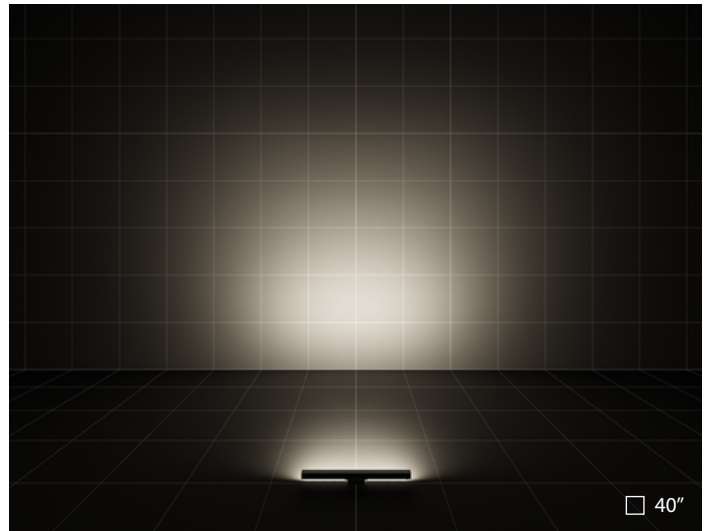

STRIP SQUARE+ | A/M 18° Asymmetric Medium optics | NEMA 5H x 4V

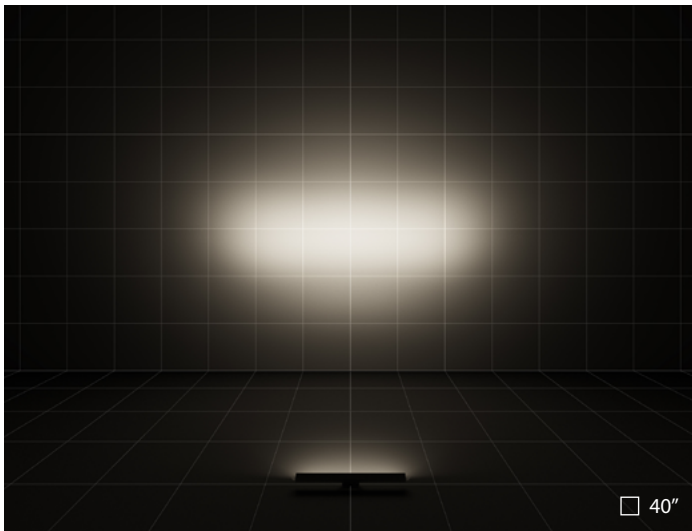

STRIP SQUARE+ | ELL 15°x45° Elliptical optics

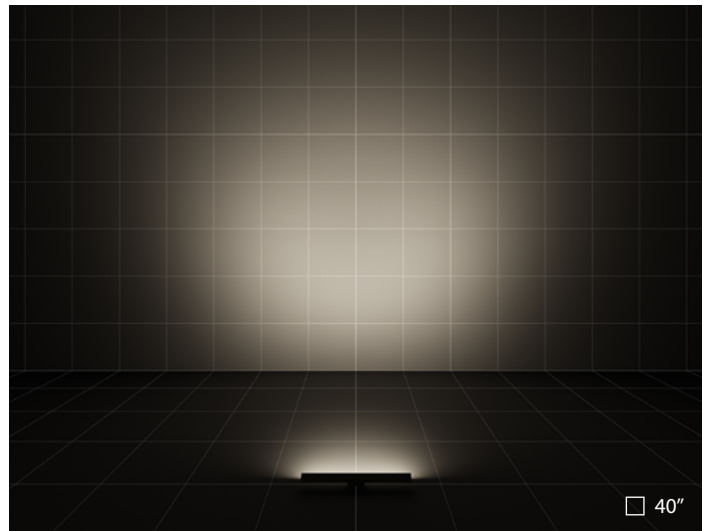

STRIP SQUARE+ | ELL 40°x60° Elliptical optics

STRIP SQUARE+

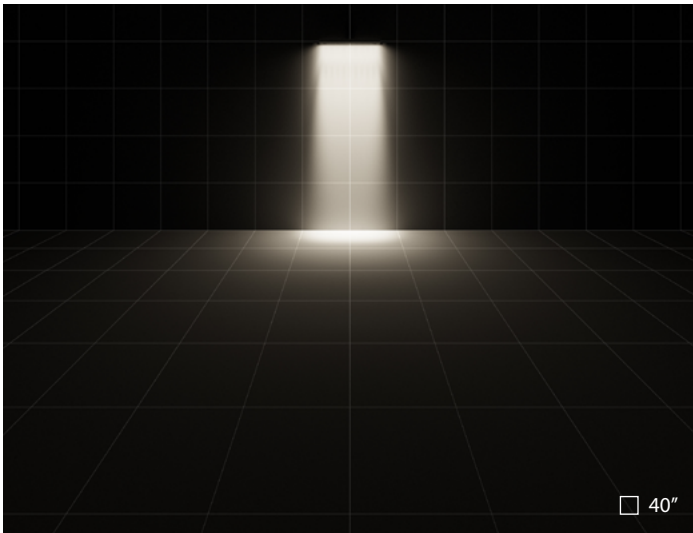

STRIP SQUARE+ | C/I 9° Circular Intensive optics

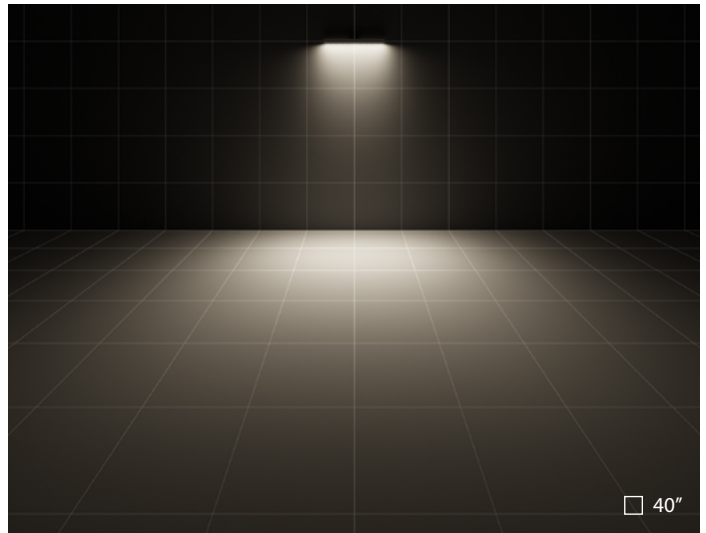

STRIP SQUARE+ | A/M 18° Asymmetric Medium optics | NEMA 5H x 4V

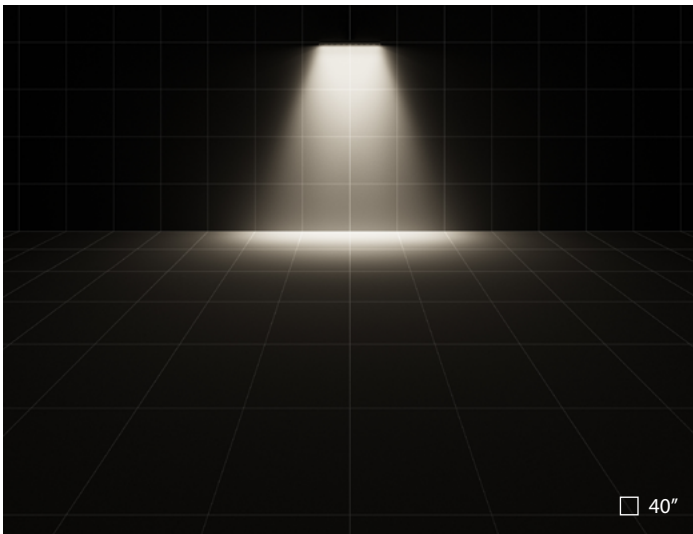

STRIP SQUARE+ | ELL 15°x45° Elliptical optics

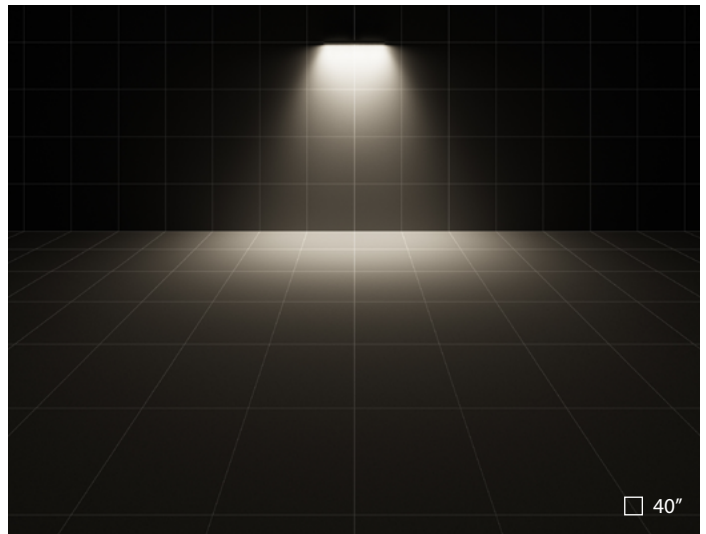

STRIP SQUARE+ | ELL 40°x60° Elliptical optics

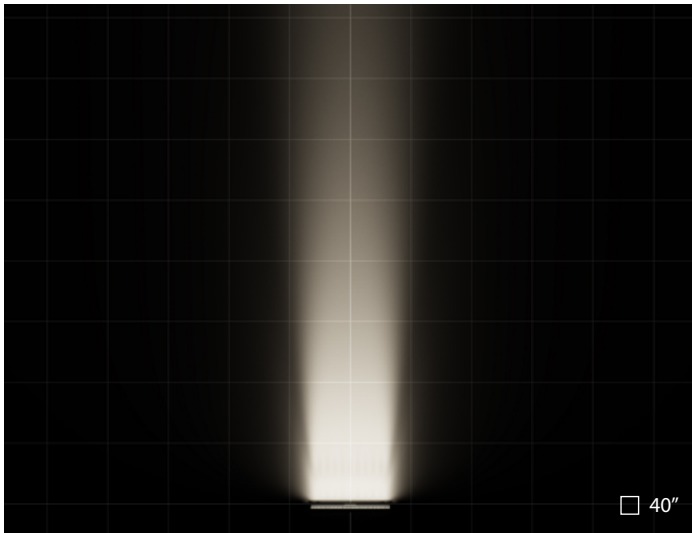

STRIP SQUARE+ | C/I 9° Circular Intensive optics

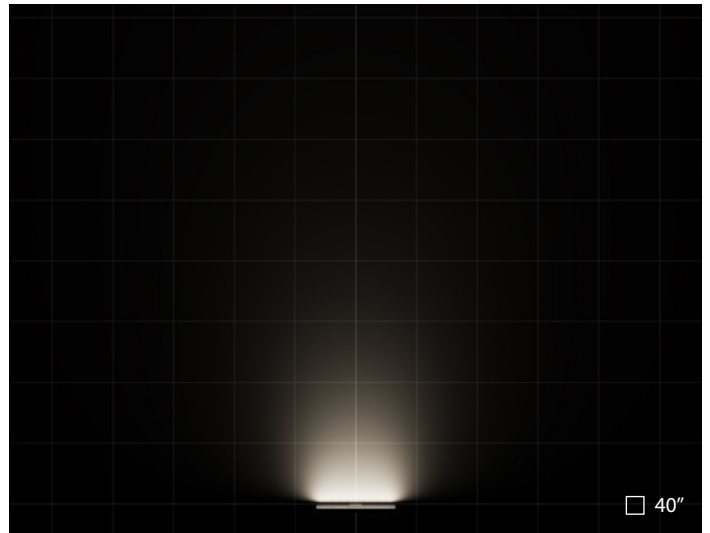

STRIP SQUARE+ | A/M 18° Asymmetric Medium optics | NEMA 5H x 4V

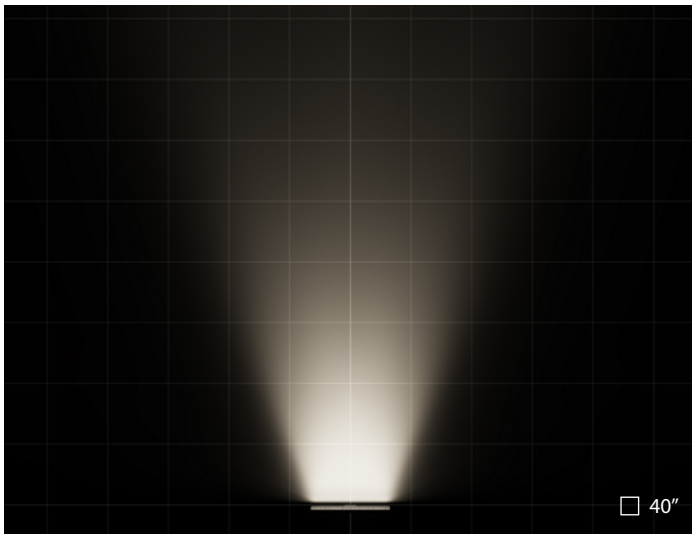

STRIP SQUARE+ | ELL 15°x45° Elliptical optics

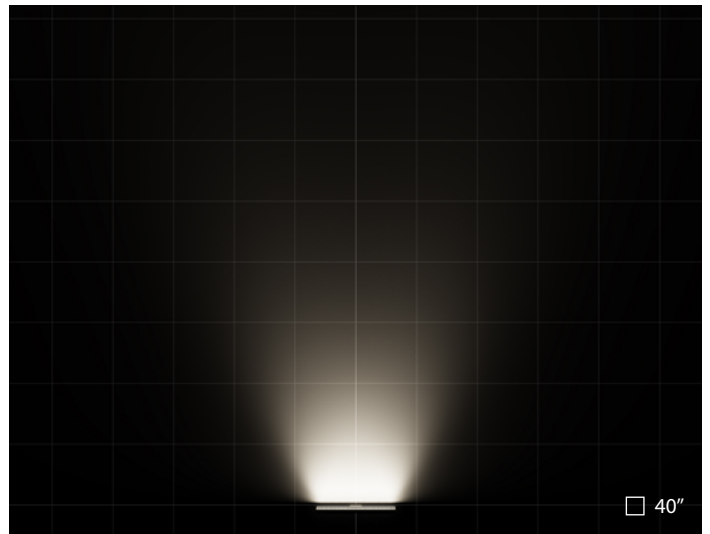

STRIP SQUARE+ | ELL 40°x60° Elliptical optics





Valetti cellar | Verona | Italy

# STRIP SQUARE+ INGROUND



Walk-over and driver-over rated.



Stainless steel tear-proof grounding tether included.



Every recessed fixing kit is fitted with a protective cover to avoid any deformations during phases of installation in cement.

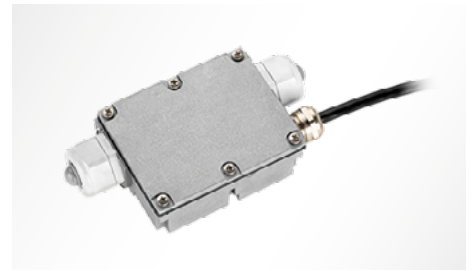

Pre-wired cable connects luminaire with WATER-STOP connection system, suitable for through wiring. Included cable glands accept cables from Ø0.35" up to Ø0.63".

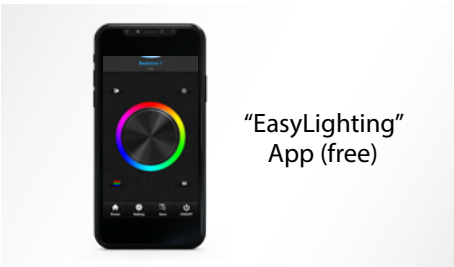

"EasyLighting" App (free)

EasyLighting is an application that uses a WIFI network to control, adjust, and customize the lighting color or CCT, brightness, and the rate of change. With this application you can control EasyLighting products through most mobile devices.



RGBW

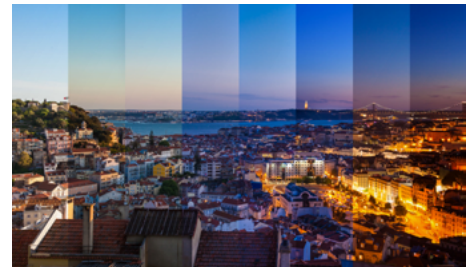

Tunable White

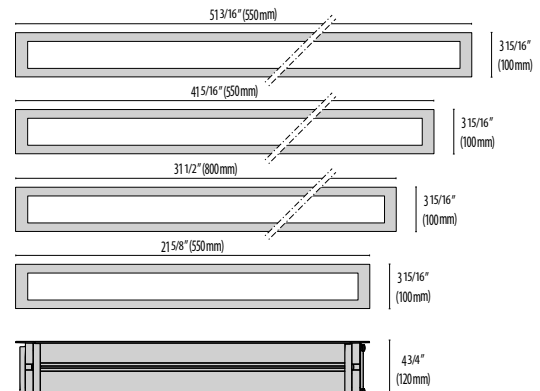
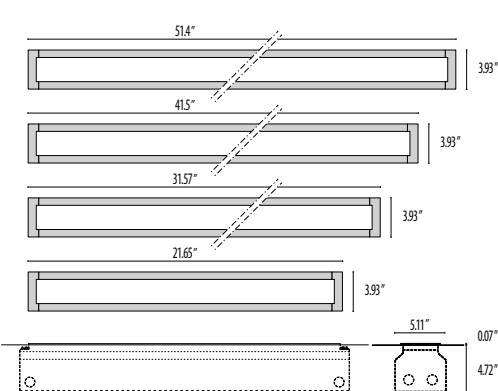

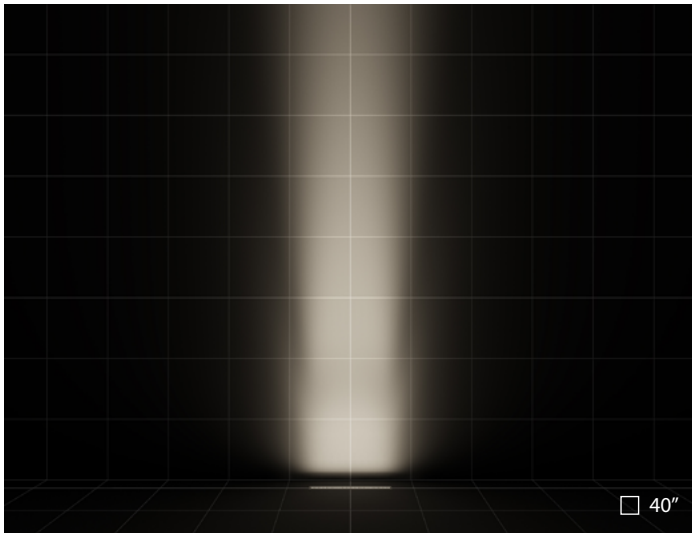

STRIP SQUARE+ INGROUND | C/I 9° Circular Intensive optics

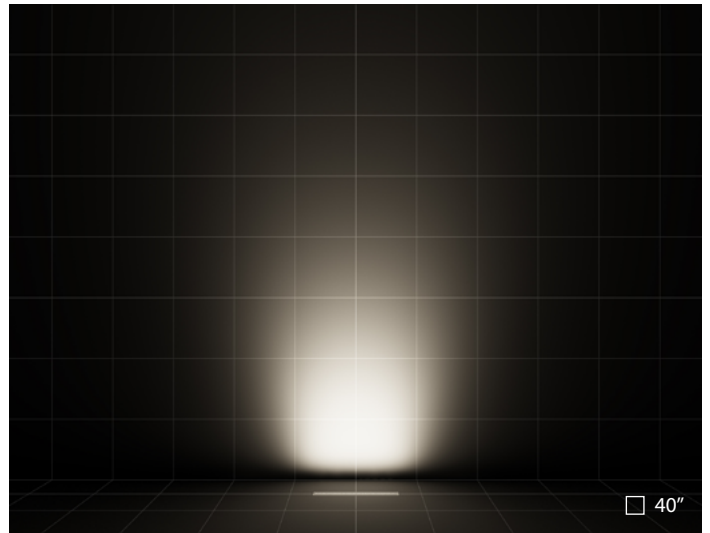

STRIP SQUARE+ INGROUND | A/M 18° Asymmetric Medium optics | NEMA 5H x 4V

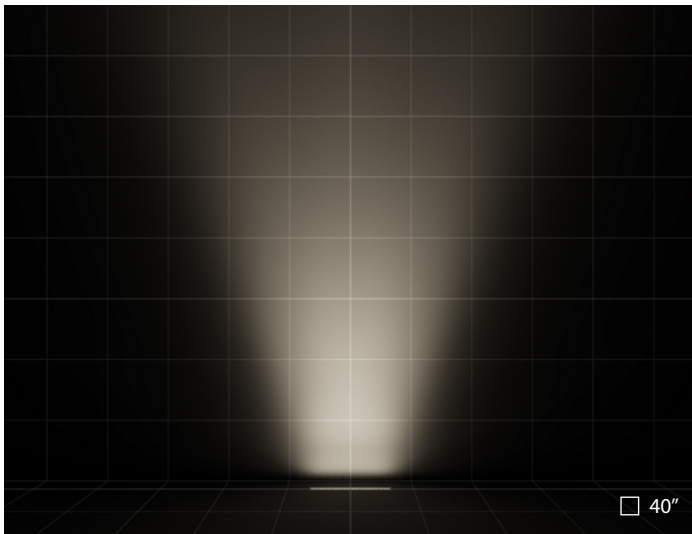

STRIP SQUARE+ INGROUND | ELL 15°x45° Elliptical optics

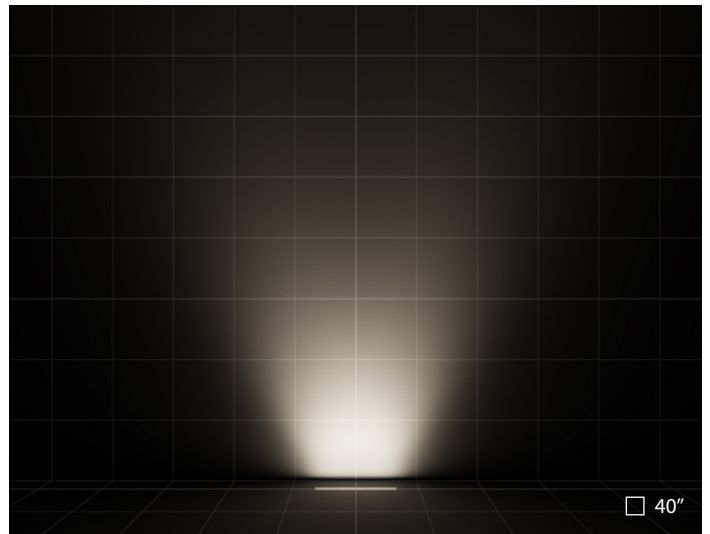

STRIP SQUARE+ INGROUND | ELL 40°x60° Elliptical optics







PERFORMANCE  
**IN** LIGHTING

powered by  
**GEWISS**

**PERFORMANCE IN LIGHTING**  
2621 Keys Pointe  
Conyers, GA 30013 - United States  
Ph 770.822.2115  
Fax 770.822.9925

[www.performanceinlighting.com](http://www.performanceinlighting.com)